

System Layout

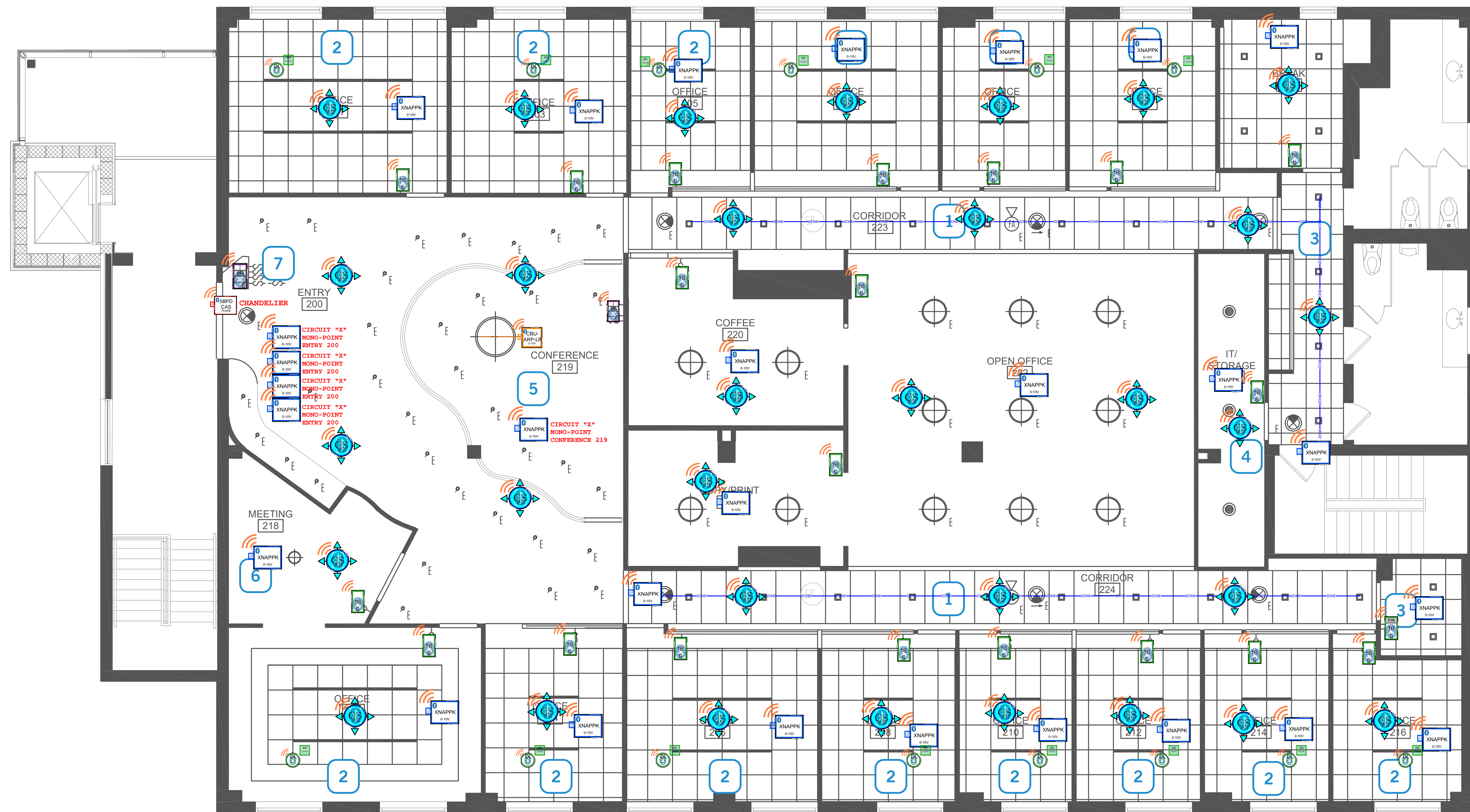

- Final installation location by installer on site.
- No Dimming Driver type specified, assuming 0-10v for quoting purposes only.
- Dedicated line voltage required for Time Keeper and Range Extender.
- Verify all wattages for lighting zones/loads/circuits previous to install.

- 1 Lighting & Controls layouts for Quote only. Not for Construction
- 2 Final installation location by installer on site.
- 3 Quantities assumed for quoting only. Final Qty by project management
- 4 No Dimming Driver type specified, assuming 0-10v for quoting purposes only.
- 5 Keypad and Sensor counts and locations assumed for quote only. Final count by installer/project manager
- 6 Lighting Zones/Loads/Branch Circuits assumed for quoting only. Final Electrical layout by Electrician on site.
- 7 Low Voltage power to be supplied by installer
- 8 Casambi White Good Nodes to be installed in glass i.e. need cover/driver enclosure, or external to the driver enclosure
- 9 Max 250 Nodes per Network. No limit on networks.
- 10 See Product Spec Sheets for exact wattage/voltage/wiring requirements.
- 11 Verify all wattages for lighting zones/loads/circuits previous to install
- 12 Dedicated line voltage required for Time Keeper and Range Extender
- 13 Keep Range Extender free of obstructions
- 14 iPad w/ Casambi App for overall scene and timer control, provided by installer

Revision Info

Plan Version: xxxxxxxxxxxx
 Plan Issued Date: _____
 Casambi Version: v2

Design Type

Quote
 Quote Revision
 Submit
 Submit Revision

General Notes

General Notes or Email Copy/paste here

Lighting & Controls layouts for Quote only. Not for Construction

Bill of Materials

CASAMBI HARDWARE		
	Description	Quantity
	CBU-ARP-LR - 1ch 0-10v w/ relay controller module	1
	CES/I-B-CS - Photodiode Sensor with BLE Compliant output	14
	FDLR05BPD-CAS - Phase Angle Dimmer, 600W, 120 Vac Power, Receiver/Repeater	1
	PSC-AC-PP-400 - 120/277V power pack, 12vdc PS	14
	PSC-DM-I-WS-100-BLE-CB -1 Button Keypad w/ OCC	1
	PSC-DM-WS-100-BLE-CB - 1 Button Keypad	20
	PSC-TKP-200-BLE-CB - Line Voltage Time Controller - Line Voltage Time Controller	1
	WS-TA08-02-1W - Atom In-Wall Switch, Relay on/off for AC, 8 Buttons	2
	XNAPPK DALI-0-10V-1CH-CAS - 1ch 0-10v/DALI 16a w/ 12/24vvaux Room Controller	28
	XNASSR-PDS-BAT-CAS - Sensor Ceiling Mount, PIR and LUX, 10yr Battery, Casambi Mesh	32

Wiring Diagrams

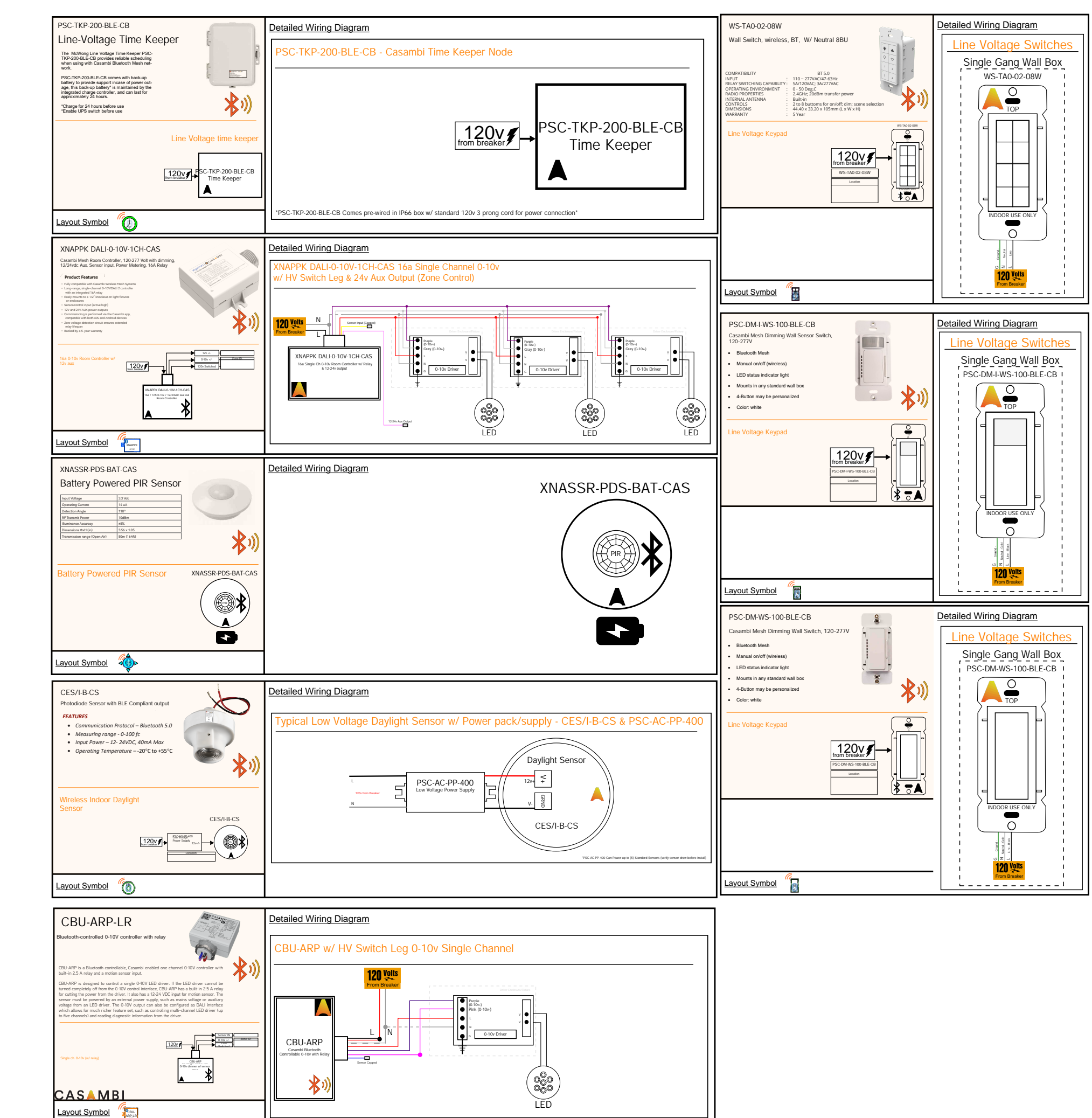

PROJECT	
ARMONK	
QUOTE TYPE	
ARMV2	QUOTE REVISION 11/25/25
Lighting Rep / OEM Partner	
KAY LIGHTING	
Project Contact	
GRETCHEN DUFFUS	
Project ID	
2025441	
Sales Contact	
ROBERTO COTES	
Designed By	
JAVIER SILVA	
A.0	

CASAMBI

Casambi Technologies, Inc.
 Atlanta, GA USA
 +1(800) 674-3548
 info@casambi.com
 us.orders@casambi.com

Specification

1	All Devices to be installed in location shown on the layout and in accordance with the ranges and mounting heights listed on the specification sheet. To ensure the integrity of the Mesh Network, Remote location of any B.E. Casambi Enabled Device could result in communication issues.
2	Final Install Locations & Wiring to be verified by installer on site before wiring. All Casambi Devices operate via Bluetooth Low Energy wireless signal. Installing devices in closets, metal boxes, remote areas will result in loss of signal.
3	Installer to verify all Voltages and Wattages of Fixtures and Lighting Zones before installation. Reference Spec Sheets and Product Information along with Detailed Wiring of each device before install.
4	Casambi Devices and Layout based on scope/documents/information provided by Lighting Rep/Architect/Designer/Specialist/etc.
5	Dimming & Control based on provided fixture/lighting schedule. Control will be assumed and noted if into is provided. Installer and Project Manager to verify dimming and control before installation/ordering.
6	Keypad and Sensor locations shown on plans for detail/count only. Final location and quantity by project manager and to be approved before ordering/installation.
7	Casambi Network size not to exceed 250 nodes per network. Verify network/LAN needs for multiple networks (site).
8	Control Intent and/or Sequence of Operations to be provided by Project Manager before scheduled dates.
9	All EM Power Generators/Inverters to be provided and specified by Project/GC/EC
10	UL/24 Devices Specified based on information provided/design of the EM Lighting System. Project/GC/EC to verify UL/24 needs and operation before installation.
11	Any install materials, junction boxes, cover plates, panels, NEMA boxes, and IP Enclosure to be provided by the installer.
12	Power supplies for Casambi devices provided as noted. Any power supplies/drivers directly for lighting to be supplied via the lighting manufacturer.

*The wireless range of a Casambi unit is dependent on several factors; how it has been integrated into a luminaire, where it has been installed; taking into consideration surrounding obstacles such as walls and other building materials that may block signals.

COMPATIBLE DEVICES

Compatible devices: Android and iOS Operating Systems.

We support the latest OS versions for Android and iOS, and their last two major versions respectively.

Tablets Smartphones

SECTION 26 09 43 DISTRIBUTED DIGITAL LIGHTING CONTROL SYSTEM	
1.1 GENERAL	1.1.1 SECTION INCLUDES A. Distributed Digital Lighting Control System; System Includes 1. Emergency Lighting Control System.
1.2 RELATED SECTIONS	A. Section 26 05 00 - LUMINAIRE B. Section 26 02 00 - Emergency Lighting C. Section 26 05 00 - Integrated Automation, Building Management and Control Systems D. Section 26 05 00 - Integrated Automation, Building Management and Control Systems
1.3 REFERENCES	A. IFC - International Code Book B. UL - Underwriters Laboratories, Inc. Listing C. UL 2042 - Standard for Fire Test for Heat and Visible Smoke Release for Discrete Products Installed in Architectural Schemes D. UL 924 - Standard for Emergency Lighting and Power Equipment E. IEC - International Electrotechnical Commission F. IEC - International Electrotechnical Commission
1.4 DESIGN / PERFORMANCE REQUIREMENTS	A. Wireless lighting system shall include integrated lighting fixture control, occupancy sensing, wall switches, occupancy sensors and accessories. B. System shall comply with IFC occupancy standards specified in part 16, subpart 1 for commercial and residential applications. C. System shall be tested under UL sections 916 and/or 908.
1.5 SUBMITTALS	26 09 43-1

SECTION 26 09 43-2	
1.1 GENERAL	1.1.1 SECTION INCLUDES A. Distributed Digital Lighting Control System; System Includes 1. Emergency Lighting Control System.
1.2 RELATED SECTIONS	A. Section 26 05 00 - LUMINAIRE B. Section 26 02 00 - Emergency Lighting C. Section 26 05 00 - Integrated Automation, Building Management and Control Systems D. Section 26 05 00 - Integrated Automation, Building Management and Control Systems
1.3 REFERENCES	A. IFC - International Code Book B. UL - Underwriters Laboratories, Inc. Listing C. UL 2042 - Standard for Fire Test for Heat and Visible Smoke Release for Discrete Products Installed in Architectural Schemes D. UL 924 - Standard for Emergency Lighting and Power Equipment E. IEC - International Electrotechnical Commission F. IEC - International Electrotechnical Commission
1.4 DESIGN / PERFORMANCE REQUIREMENTS	A. Wireless lighting system shall include integrated lighting fixture control, occupancy sensing, wall switches, occupancy sensors and accessories. B. System shall comply with IFC occupancy standards specified in part 16, subpart 1 for commercial and residential applications. C. System shall be tested under UL sections 916 and/or 908.
1.5 SUBMITTALS	26 09 43-2

SECTION 26 09 43-3	
1.1 GENERAL	1.1.1 SECTION INCLUDES A. Distributed Digital Lighting Control System; System Includes 1. Emergency Lighting Control System.
1.2 RELATED SECTIONS	A. Section 26 05 00 - LUMINAIRE B. Section 26 02 00 - Emergency Lighting C. Section 26 05 00 - Integrated Automation, Building Management and Control Systems D. Section 26 05 00 - Integrated Automation, Building Management and Control Systems
1.3 REFERENCES	A. IFC - International Code Book B. UL - Underwriters Laboratories, Inc. Listing C. UL 2042 - Standard for Fire Test for Heat and Visible Smoke Release for Discrete Products Installed in Architectural Schemes D. UL 924 - Standard for Emergency Lighting and Power Equipment E. IEC - International Electrotechnical Commission F. IEC - International Electrotechnical Commission
1.4 DESIGN / PERFORMANCE REQUIREMENTS	A. Wireless lighting system shall include integrated lighting fixture control, occupancy sensing, wall switches, occupancy sensors and accessories. B. System shall comply with IFC occupancy standards specified in part 16, subpart 1 for commercial and residential applications. C. System shall be tested under UL sections 916 and/or 908.
1.5 SUBMITTALS	26 09 43-3

Sequence of Operatic

Default Sequence Of Operations

- In the event that a customer-approved sequence of operations is not provided prior to or at the start of this startup visit, the Casambi Field Service Representative will program the system using the framework outlined below.
- Any modifications to the default sequence of operations after the startup has commenced may incur additional fees.
- Fixture Groupings, Areas, and Naming:

Spaces with individual fixture controllers:

- In installations where there are fewer remotes and/or wall stations than there are fixture controllers, the remotes and wall stations will be distributed to control an even number of grouped fixtures, to the best extent allowed by the installed lighting controllers.

Spaces without individual fixture controls:

- In small and medium-sized spaces (e.g., conference rooms, bathrooms, offices, classrooms): all controllers will be grouped and controlled as one area.
- In large-sized spaces (e.g., open offices, lecture halls, ballrooms): all controllers in the space will be grouped as one area, and the controls (e.g., remotes, wall stations, sensors) will be distributed to control an even number of fixture groupings based on the proximity of the controllers to the controls.
- The term "Space," as used above, is defined as an architecturally defined space – which may or may not be defined by walls – with a clearly distinct use. Casambi Field Service Representatives will exercise their professional judgment in determining what constitutes a space in cases where spaces are not defined by a customer-approved sequence of operations.

Naming Conventions:

During startup, a Casambi Field Service Representative will name all applicable devices and areas in the software using an agreed-upon or logical naming convention.

- Wireless remotes and wall stations:**
 - One button: Toggle lights on and off.
 - Two buttons: Top button will turn lights on, and the bottom button will turn lights off.
 - Three buttons: Top button will turn lights on, middle button will be set to a 50% light level, and the bottom button will turn the lights off.
 - Four buttons: Top button will set lights to a 100% light level, 2nd button down will set lights to a 65% light level, 3rd button down will set lights to a 35% light level, and the bottom button will turn lights off.
 - Five buttons (3 buttons with raise/lower): Top button will turn lights on, middle button will be set to a 50% light level, and the bottom button will turn the lights off.
- Occupancy/vacancy sensor timeout:**
 - In spaces with remotes and/or wall controls, sensors will be set up as vacancy sensors (only automatically turning off the lights) with a 15-minute (+/- 1-minute) timeout.
 - In spaces without remotes and/or wall controls, sensors will be set up as occupancy sensors (automatically turning the lights on and off) with a 15-minute (+/- 1-minute) timeout.
- Daylight sensor:**
 - Sensors without auto-calibration will be calibrated to achieve 40 foot-candles (+/- 5 foot-candles) from roughly three (3) feet (91 cm) off the floor at a distinct point in the room – typically the center of a room. Note that the consistency of light distribution throughout the space is highly dependent upon fixture design and placement.
 - In small or medium-sized spaces, the daylight sensor will affect the entire area (see Fixture Groupings, Areas, and Naming section on the left).

Typical Drawings

Integrated Driver (@ fixture location)

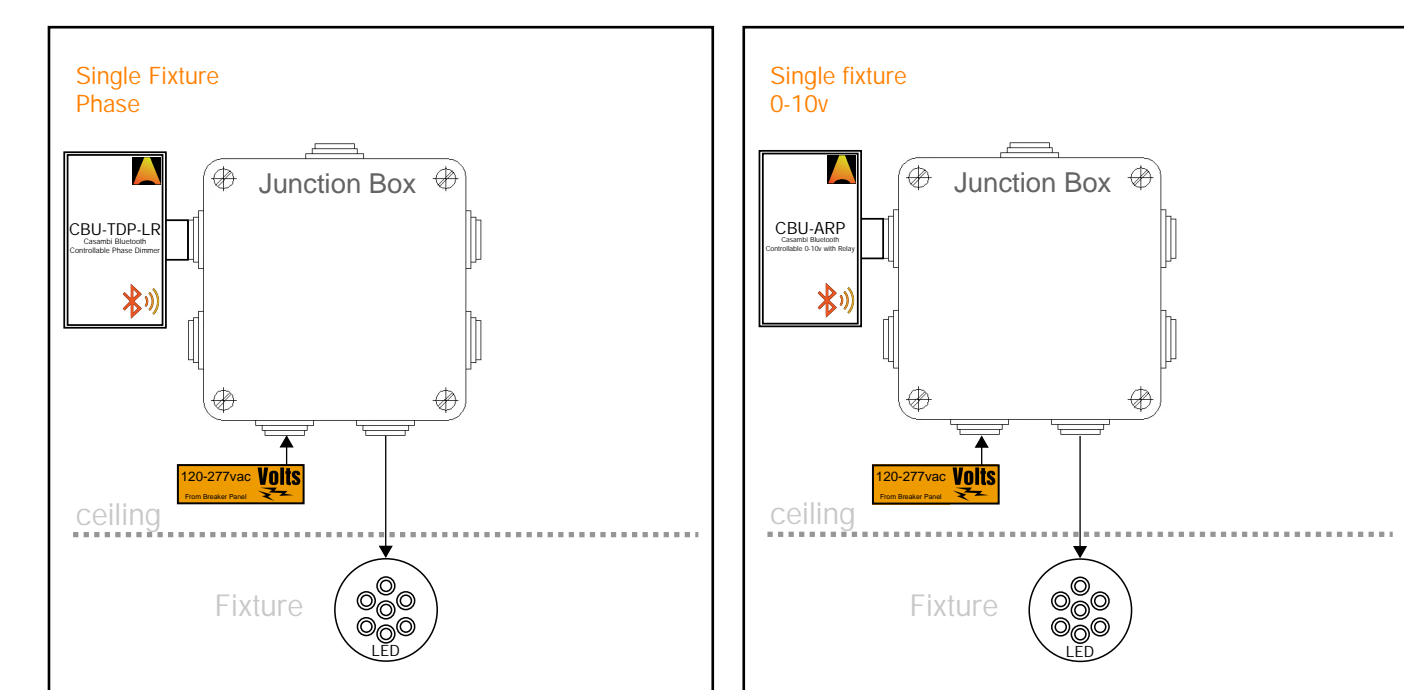

Multiple Fixture Zone 0-10V

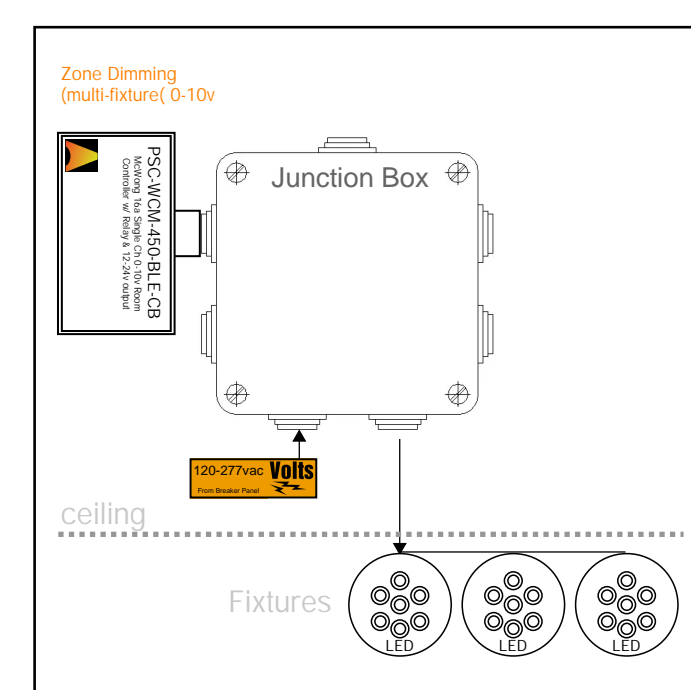

Remote Driver (Driver location)

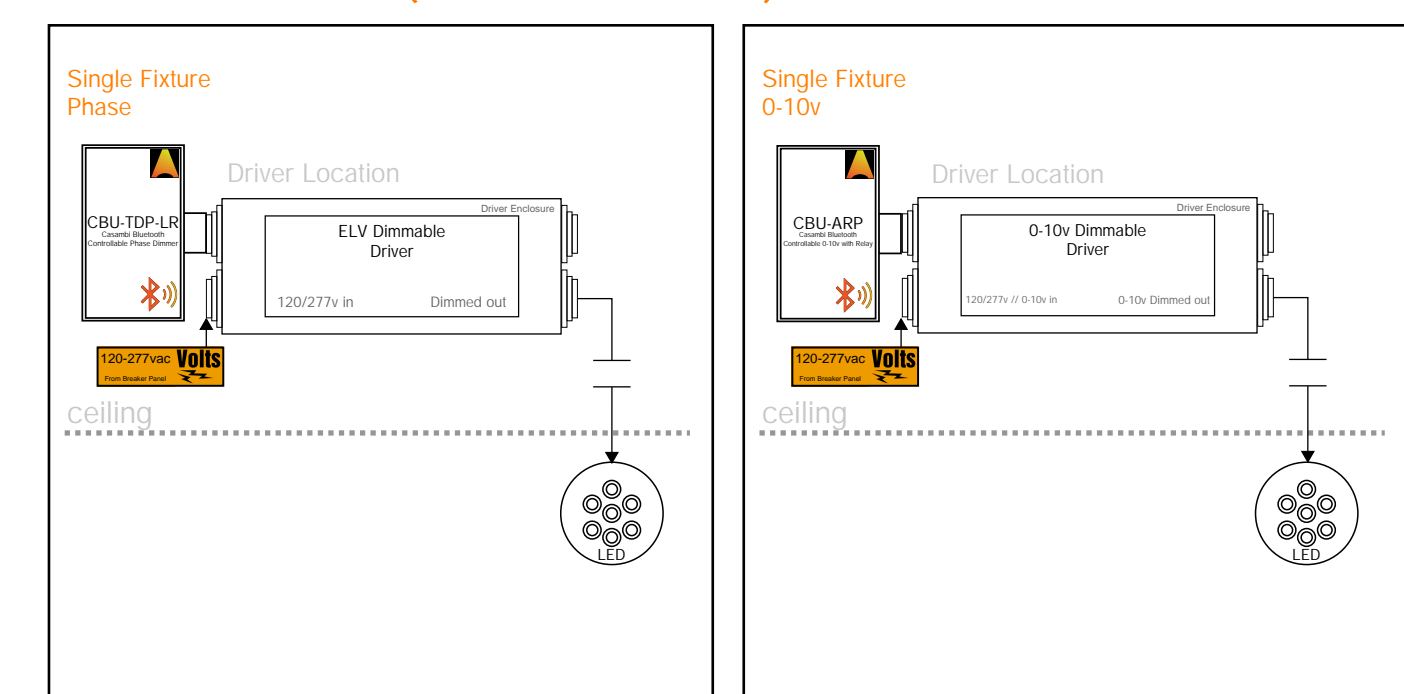

Multiple Fixture Zone Phase

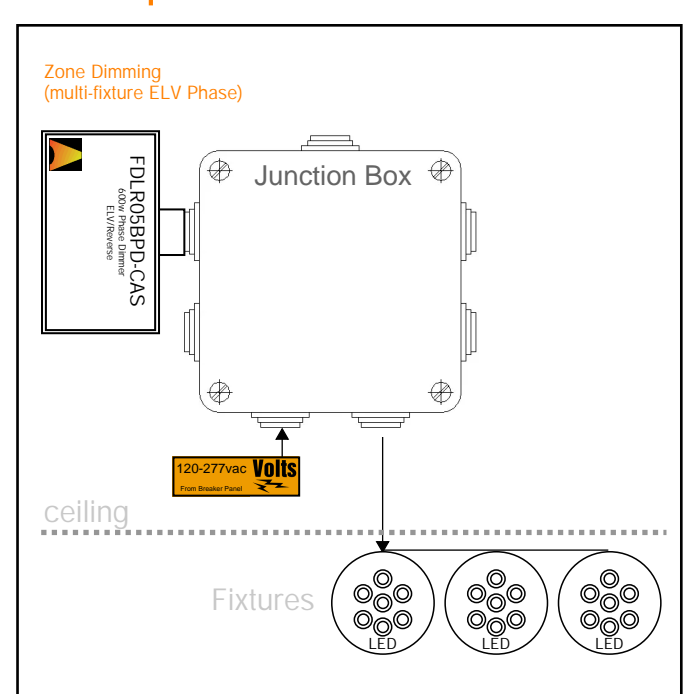

See Wiring Detail page for detailed wiring diagrams

Internal Installation (inside Driver Enclosure)

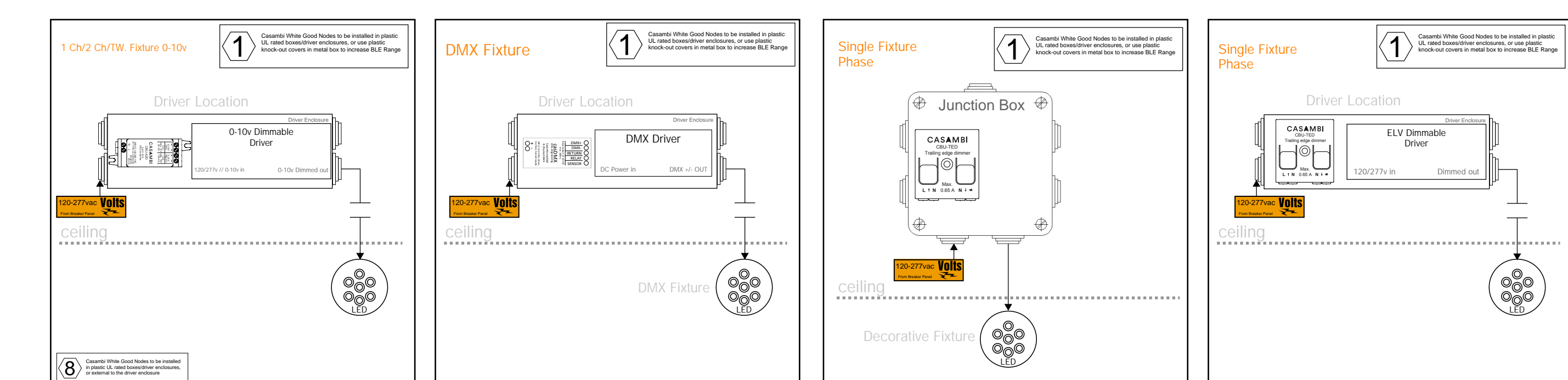

Low Voltage RGBW/LED Strip/Lineair

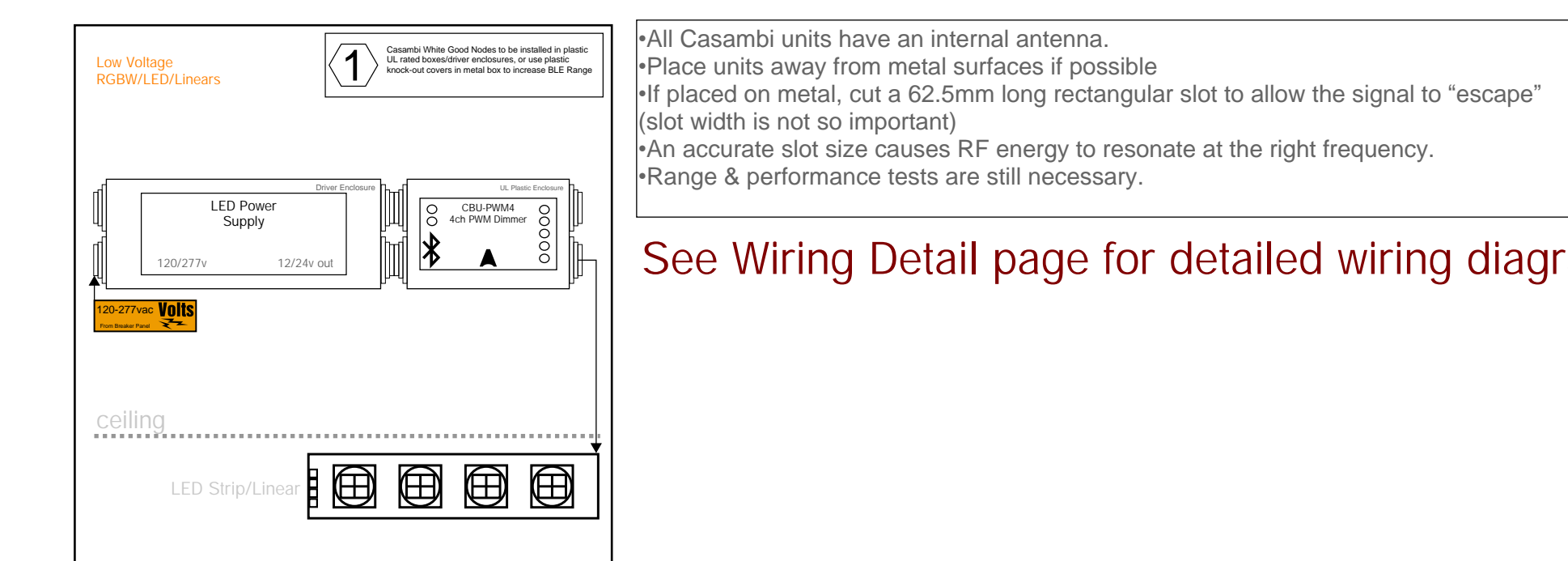

Casambi Services

Additional Services

Select your visit type and quantity from a la carte menu.

Select	Quantity	Model Number/Description
<input type="checkbox"/>		CAS-AH-SERVICE Conversion from normal business hours to afterhours for an on-site visit conducted between the hours of 8:00 pm and 8:00 am.
<input type="checkbox"/>		CAS-CERT-SERVICE On-site comprehensive testing and verification with thorough documentation and site walk with third-party commissioning agent.
<input type="checkbox"/>		CAS-DES-SERVICE Design Services: Precision of essential project documentation not provided to the controls company, incorporating, but not limited to Lighting/Zone Schedules, Comprehensive Riser/Single Line Diagrams, and Sequence of Operations.
<input type="checkbox"/>		CAS-ENG-SERVICE Engineering Services: Development and oversight of Submittal Documentation, inclusive of all requisite revisions and documentation necessary for project approval.
<input type="checkbox"/>		CAS-INTEGRATE On-site or remote review of third-party equipment and/or BMS systems to establish proper integration to control system.
<input type="checkbox"/>		CAS-ON-TRAIN On-site detailed training on overall system operations and maintenance will be provided during the visit.
<input type="checkbox"/>		CAS-PREVIEW On-site pre-consultation discussing best practices, in-depth review of submittal, equipment locations, sequencing of additional desired sequence of operations, and confirmation of project timeline and phases. The visit duration is 4 hours.
<input type="checkbox"/>		CAS-RAM-TRAIN Remote detailed training on overall system operations and maintenance will be provided during the visit.
<input type="checkbox"/>		CAS-SERV-2 One 3-hour on-site visit will take place between 8:00 am and 5:00 pm, Monday through Friday.
<input type="checkbox"/>		CAS-SERV-4 One 3-hour on-site visit will take place between 8:00 am and 5:00 pm, Monday through Friday.
<input type="checkbox"/>		CAS-SERV-8 One 3-hour on-site visit will take place between 8:00 am and 5:00 pm, Monday through Friday.
<input type="checkbox"/>		CAS-800 On-site detailed system programming with the guidance of a lighting designer, commissioning agent, and/or End User.

Start-up & Commissioning

Cas-Startup

Visit Description

On-site visits will occur between 8:00 am and 5:00 pm, Monday through Friday. Additional fees may apply for work outside these hours.

The duration of a startup visit may span multiple days based on the system's size. Casambi Services Scheduling can estimate the duration, but any deviation from the estimate for the original agreed-upon scope of work does not impact the price. Refunds will not apply for any estimated unused days.

A Casambi Field Service Representative is eligible to provide up to eight (8) contiguous hours of work per day during this visit. Please consult your Casambi Sales Representative if more than eight (8) contiguous hours are required.

A customer-approved sequence of operations will be submitted to Casambi before the on-site visit. This sequence must clearly outline to the Casambi Field Service Representative how the system is intended to be programmed in each space, specifying the expected associations between devices (i.e., identifying which sensors should be linked to which load controllers).

If, by the commencement of this visit, a customer-approved sequence of operations is not available, the Casambi Field Service Representative will program the system according to the default sequence of operations provided. A comprehensive sequence of operations should encompass groupings of controlled fixtures, details on controllers, sensor behavior, and timelock schedules.

Introductory training on overall system operations and maintenance will be provided during the visit.

A summary of completed work will be provided at the end of the visit.

Incorporating a "CAS-ENG-SERVICE" line item into your purchase order signifies your acceptance and acknowledgment of the sequence of operations and bill of materials delineated within your submittal package.

Important Information

Casambi requires 10 business days' notice to schedule an on-site visit.

- The facility representative is responsible for coordinating the required visit attendees.
- The facility representative should ensure access to the required areas is secured prior to the visit date.
- All items listed in the project's bill of materials must be installed and powered up during the startup process.
- Casambi must be notified in advance regarding any project phasing. Startup, defined as consecutive days, cannot be divided without proper planning.
- Casambi representatives will not perform work on non-Casambi equipment.
- The replacement of controls damaged due to miswiring, incorrect installation, or any other related issue not covered under the Casambi warranty is the responsibility of the installer.
- Field wiring changes or corrections that cause delays in the startup process, necessitating extra time for Casambi to complete the startup, will result in additional charges.
- Programming or any other changes that deviate from the approved submittal sequence of operations must receive approval through the appropriate channels and may incur additional charges.

Engineering Services

CAS-ENG-SERVICE
Our combined Design and Engineering Services offer a comprehensive solution for your project needs. This includes the creation of essential project documentation not typically provided to the controls company, such as Lighting/Zone Schedules, detailed Riser/Single Line Diagrams, and through Sequences of Operations. Additionally, we handle the development and management of Submittal Documentation, ensuring all necessary revisions and documentation are completed for project approval.

00K	10K	2%
10K	30K	4%
30K	UP	5%
Percentage X BOM Total		

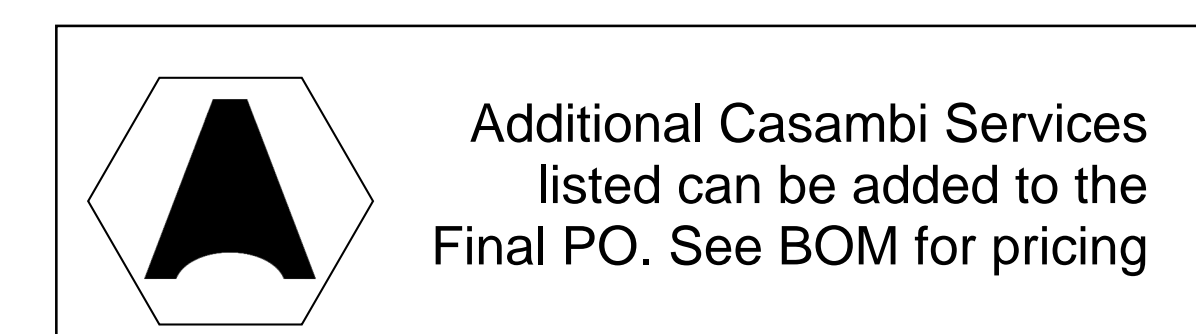

AC Powerpack Controller

XNAPPK DALI-0-10V-1CH-CAS



CASAMBI



Product Features

- Fully compatible with Casambi Wireless Mesh Systems
- Long-range, single-channel 0-10V/DALI 2 controller with an integrated 16A relay
- Easily mounts to a 1/2" knockout on light fixtures or enclosures
- Sensor/control input (active high)
- 12V and 24V AUX power outputs
- Commissioning is performed via the Casambi app, compatible with both iOS and Android devices
- Zero voltage detection circuit ensures extended relay lifespan
- Backed by a 5-year warranty

Environmental Specifications

Operating Temperature	-40 °C to 45 °C / -40°F to 113°F
Storage Temperature	-40 °C to 85 °C / -40°F to 185°F
Working Humidity	10% to 90%
Storage Humidity	5% to 95%
Lifetime	at Tc 75°C: 50,000 hrs @ 120 Vac
Maximum Tc temperature	85 °C / 185°F
Lifetime Rating	50,000 hrs
Moisture and Dust Rating	IP20

AC Powerpack Controller

XNAPPK DALI-0-10V-1CH-CAS

Electrical Specifications

Main Voltage Supply

Rated Input Voltage Range	100-277 Vac
Max. Input Voltage Range	108-305 Vac
Rated Frequency Range	50/60 Hz
Max. Input Current	0.04 A
No-Load Standby Power	< 0.5 W
Max. Load Current	20A resistive, 16A EB / LED
RF Transmit Power	+8 dBm
Turn-On Delay Time	<0.5 seconds
Max. 0 –10V Sinking Current	100 mA
Wireless Frequency	2.4GHz
Wireless Range (Open Air)	≥50 m (164ft)

Protection Against Voltage Peaks

Withstand Voltage	I/p-O/p: 1.5 kVac, < 5 mA 60 sec
Mains Surge Immunity	L-N 1 kV, L-FG 2 kV, N-FG 2 kV

Relay Contact Rating

Rated Input Voltage Range	100-277 Vac
Max. Input Voltage Range	108-305 Vac
Rated Frequency Range	50/60 Hz
Rated Input Current	20A resistive, 16A EB / LED

Output Data

Output Voltage 0-10 V	0-10 Vdc
Output Current 0-10 V	100 mA sinking
Output Voltage DALI	12 Vdc
Output Current DALI	20 mA

AC Powerpack Controller

XNAPPK DALI-0-10V-1CH-CAS

Sensor Input

Sensor Type	Motion (ON/OFF)
Input Voltage	12-24 Vdc
Input Current	1-5mA

Connection Terminals

Fixed Device	Locknut with 1/2" NPT-thread
Mains Input L	12 AWG
Mains Input N	18 AWG
Relay Output	12 AWG
Low voltage sensor input	18 AWG
Low voltage output (0-10V/DALI)	22 AWG

Environmental Specifications

Operating Temperature	-40 °C to 55°C
Storage Temperature	-40 °C to 85°C
Working Humidity	10% to 80%
Storage Humidity	5% to 95%
Lifetime	at Tc 75°C: 50,000 hrs @ 120 Vac
Maximum Tc Temperature	85°C
Lifetime Rating	50,000 hrs
Moisture and Dust Rating	IP20
Wireless Range (Open Air)	≥50 m (164ft)

AC Powerpack Controller

XNAPPK DALI-0-10V-1CH-CAS

Product Dimensions

Housing Dimensions

Length	70 mm / 2.76in
Width	68mm / 2.67in
Height	27mm / 1.06in
Weight	110g

Packaging Details

Packing Units	40 pcs
Carton Size	322x260x218 mm (12.67x10x8.6 in)
Weight	5 kg

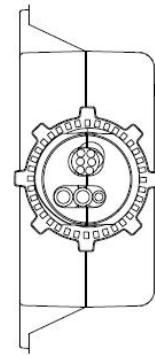
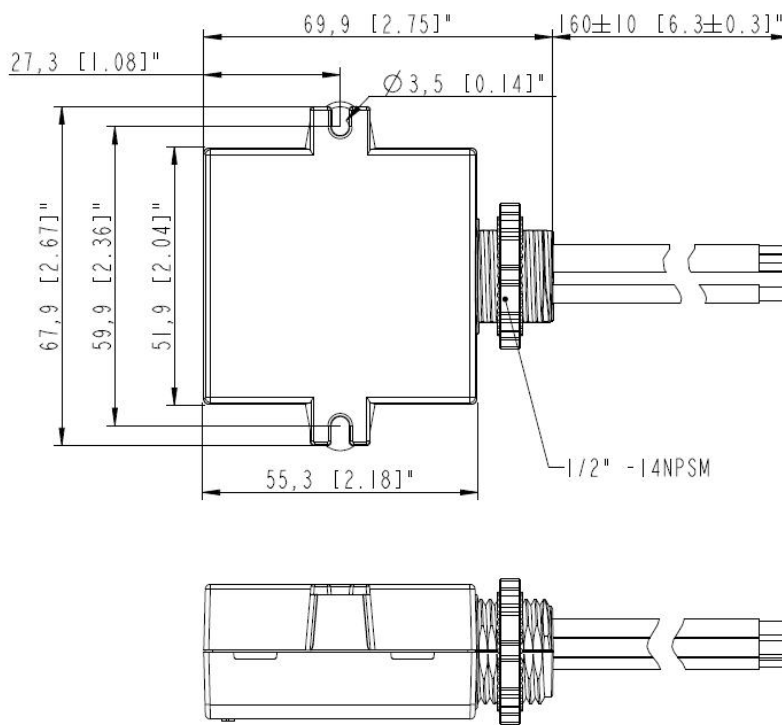

AC Powerpack Controller

XNAPPK DALI-0-10V-1CH-CAS

Wiring Diagram

Figure 1

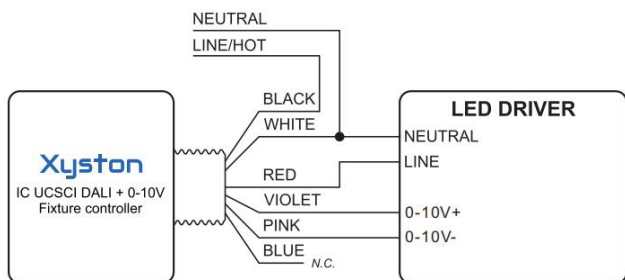

Figure 2

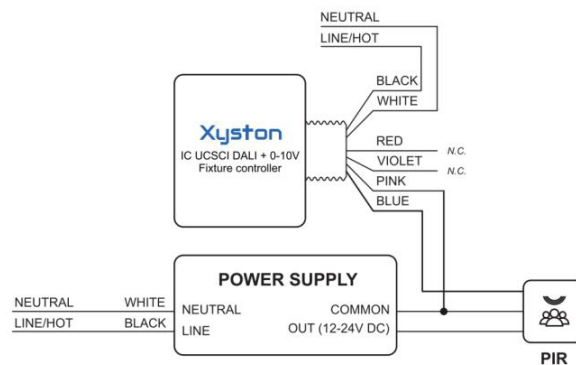

Figure 3

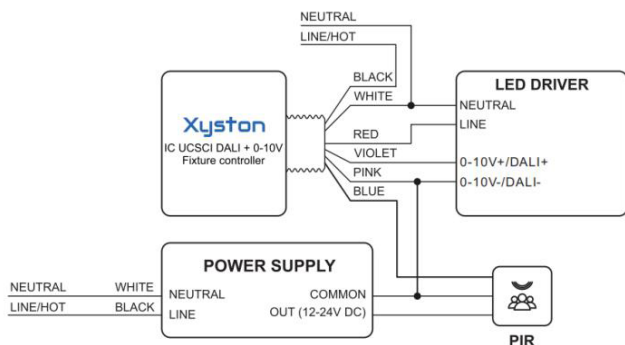

Figure 4

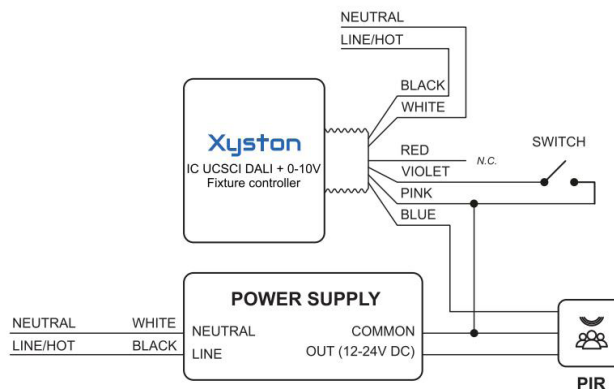

Figure 5

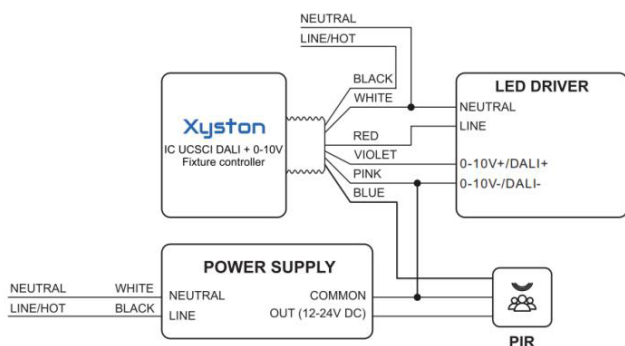
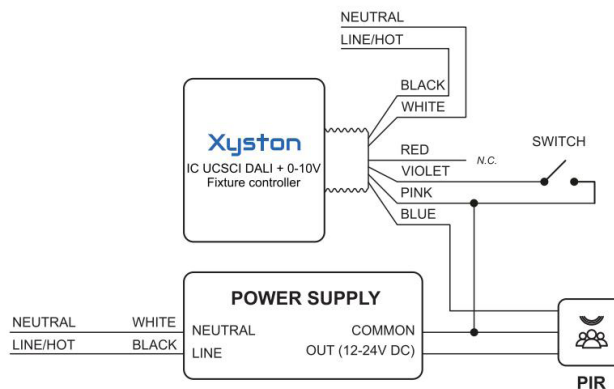

Figure 6



AC Powerpack Controller

XNAPPK DALI-0-10V-1CH-CAS

Wiring Specifications

Name	Function	Color	Gauge	Type	Length	Strip Length
L	Input Hot	Black	12 AWG	Solid	20cm / 7.78in	0.8-1cm / 0.3149-0.3149in
L1	Switched Hot out	Red	12 AWG	Solid	20cm / 7.78in	0.8-1cm / 0.3149-0.3149in
N	Neutral	White	18 AWG	Solid	20cm / 7.78in	0.8-1cm / 0.3149-0.3149in
0-10V+/DALI+	Dimming Level	Purple	22 AWG	Solid	20cm / 7.78in	0.8-1cm / 0.3149-0.3149in
0-10V-/DALI-	Low Voltage common	Pink	22 AWG	Solid	20cm / 7.78in	0.8-1cm / 0.3149-0.3149in
Sensor	Sensor high & low level input	Blue	22 AWG	Solid	20cm / 7.78in	0.8-1cm / 0.3149-0.3149in
AUX 1	12V @ 100mA	Red	22 AWG	Solid	20cm / 7.78in	0.8-1cm / 0.3149-0.3149in
AUX 2	24V @ 100mA	Yellow	22 AWG	Solid	20cm / 7.78in	0.8-1cm / 0.3149-0.3149in

- All connections must be as short as possible to ensure good EMI performance.
- No secondary switches are allowed.
- Incorrect wiring can damage the fixtures.
- The wire must be well protected against short circuit.



www.casambi.com



Casambi Knowledge Base



Download FREE Casambi iOS/Android App



Specification Library

Project: _____

Reference Type: _____

Item Code: _____

Date: _____

Notes: _____

Wireless 1-Button Wall Controller

Overview

- Casambi Wireless Mesh
- Manual on/off (wireless)
- Dim up/down (wireless)
- Scenes/Color Tuning
- ioXt Alliance cybersecurity certification
- LED status indicator light
- Mounts in any standard wall box
- Color: White



Suitable for Indoor Use Only



Applications

mwConnect's Wireless 1-Button Wall Controller (PSC-DM-WS-100-BLE-CB) wirelessly communicates using Casambi Wireless Mesh controllers to provide light level control to lighting in the space. The controller can be installed in a standard single gang wall box.

Typical applications include private offices, open office areas, lobbies, classrooms and conference rooms.

Operation

Casambi Wireless Mesh Controls: The Wall Control connects to a wireless mesh network via a mobile app, available as iOS or Android, to allow initial setup and subsequent parameters adjustments.

User Interface: Using the mobile app, features include: setup, control real time feedback, and scheduling without a gateway or internet access.

See the mwConnect Casambi Commissioning User Manual for more information.

Summary

Product Type:
Wireless Wall Controller

Input Voltage | Power Consumption:
120-277 VAC, 50/60Hz | Max 1.5W

Mounting:
Standard wall box

Max Wireless Range¹:
30ft (9.14m)

Operating Temperature:
0° to 55°C

Storage Temperature:
-10° to 60°C

Relative Humidity:
90-95% non-condensing at 30°C

Color: White

Warranty: 5 years

Note:
1. Wireless Range is highly dependent on the integration of fixtures, surrounding environment and conditions. It is recommended to conduct testing for range accuracy.



www.casambi.com



Casambi Knowledge Base



Download FREE Casambi iOS/Android App



Specification Library

Project: _____

Reference Type: _____

Item Code: _____

Date: _____

Notes: _____

Physical Dimensions

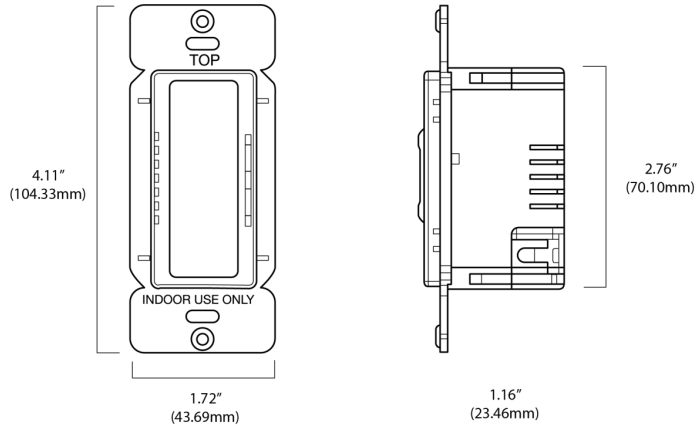

Wiring Diagram

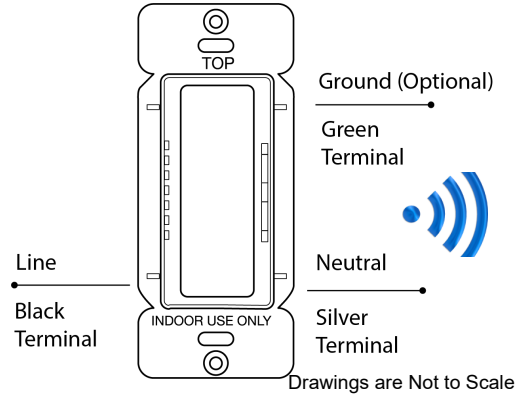

Examples

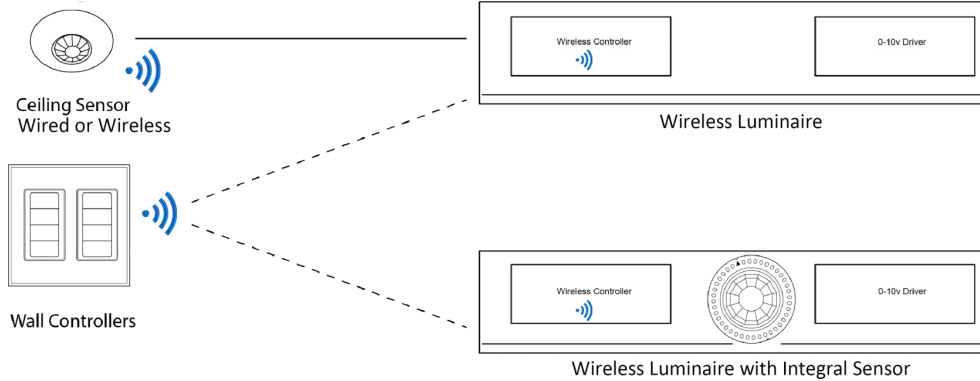

Wireless Manual Control

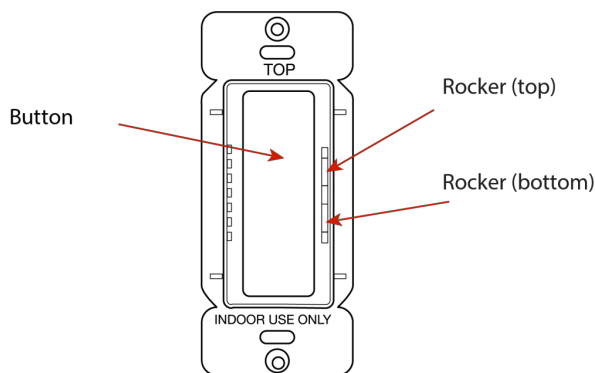

Button for On/Off:

Short press - OFF

Short press - AUTO/ON

Auto = Resume automatic control; turns on the automatic settings for luminaires (defined by the settings profile).

Rocker for dimming:

Top - Raise

Bottom - Lower

Factory reset:

Press and hold Button together with Rocker at top and bottom for 10 sec. The device returns to an un-provisioned state.

How to Order

Model No.	Description	Input Voltage
PSC-DM-WS-100-BLE-CB	Wireless 1-Button Wall Controller, mwConnect Casambi Wireless Mesh, (decorator faceplate not included)	120-277 VAC, 60Hz

Wireless Occupancy Sensor Dimming Wall Controller

Overview

- Passive Infrared (PIR) Occupancy Sensor
- Casambi Wireless Mesh
- Manual on/off (wireless)
- ioXt Alliance Cybersecurity Certification
- Dim up/down (wireless)
- LED Status Indicator Light
- Mounts in any Standard Wall Box
- Color: White



Suitable for Indoor Use Only



Applications

McWong's one button wall controller with raise/lower toggle (PSC-DM-I-WS-100-BLE-CB) communicates with Casambi Wireless mesh network devices to provide light level control to lighting in the space. The controller can be installed in a standard single gang wall box.

PIR detection is best suited for areas with clear line of sight. Typical applications include classrooms, copy rooms, private offices, conference rooms, and private restrooms.

Typical applications include public restrooms, private offices, classrooms, conference rooms, storage spaces, and break rooms.

Operation

Casambi Wireless Mesh Controls: The Wall Control connects to a wireless mesh network via a mobile app, available as iOS or Android, to allow initial setup and subsequent parameters adjustments.

User Interface: Using the mobile app, features include: setup, control real time feedback, and scheduling without a gateway or internet access.

See the McWong Casambi Commissioning User Manual for more information.

Summary

Sensor Type:
PIR Occupancy/Vacancy Sensor Dimmer

Input Voltage | Power Consumption:
120-277 VAC, 50/60Hz | Max 1.5W

Mounting:
Standard wall box

Max Range:
40 ft @ 4ft mounting height
(12.2m @ 1.2m mounting height)

Max Bluetooth Range¹:
30ft (9.14m)

Operating Temperature:
0° to 55°C

Storage Temperature:
-10° to 60°C

Relative Humidity:
90-95% non-condensing at 30°C

Color: White

Warranty: 5 years

Note:

1. Wireless Range is highly dependent on the integration of fixtures, surrounding environment and conditions. It is recommended to conduct testing for range accuracy.

Physical Dimensions

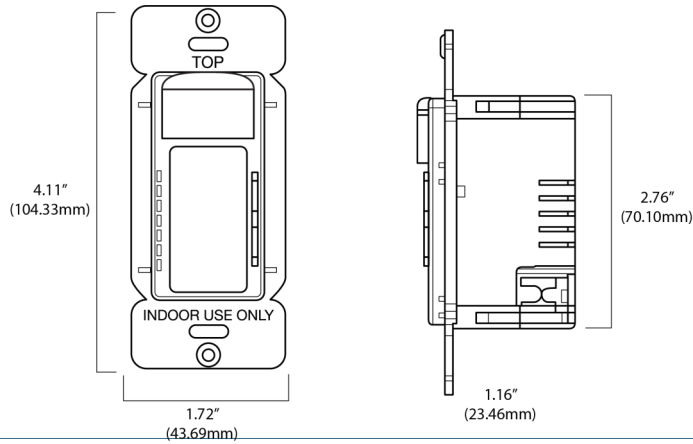

Wiring Diagram

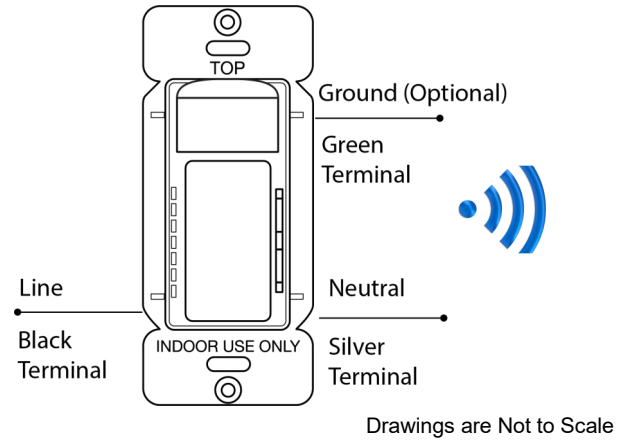

Examples

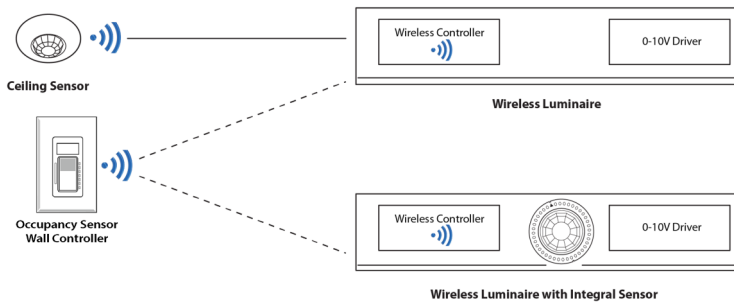

Detection Area

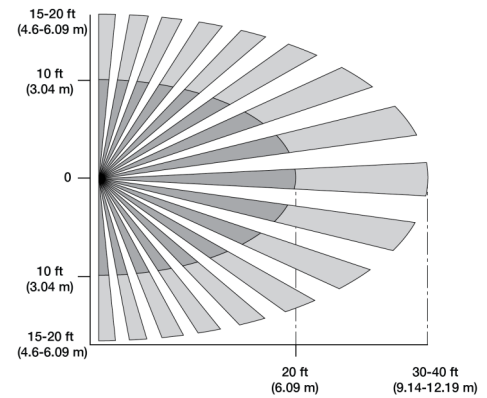

Drawings are not to scale

Wireless Manual Control

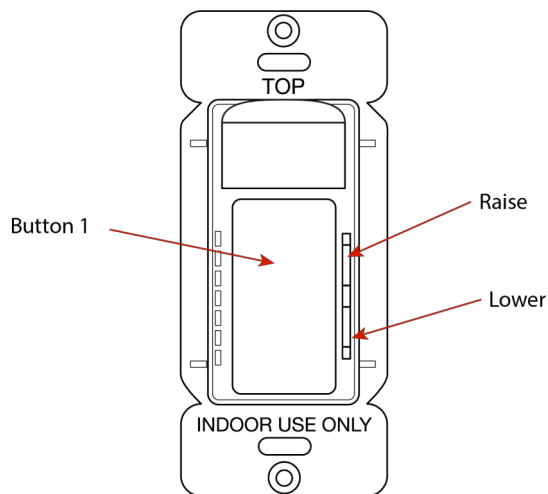

Button 1 for On/Off:

Short press - AUTO/ON

Second Short press - OFF

Auto = Resume automatic control; turns on the automatic settings for luminaires (defined by the settings profile).

For dimming:

Top - Raise Rocker

Bottom - Lower Rocker

Factory reset:

Press and hold Button together with Rocker at top and bottom for 10 sec. The device returns to an un-provisioned state.

How to Order

Model No.	Description	Input Voltage
PSC-DM-I-WS-100-BLE-CB	Wireless PIR Occupancy Sensor Dimming Wall Controller, Casambi Wireless Mesh, (decorator faceplate not included)	120-277 VAC, 60Hz

Design and specifications are subject to change without notice.



AC input wireless In-Wall Switch ATOM Series

This mechanical and electrical sound design is capable of providing multi-functions and allow wirelessly control lighting devices in various platforms. This is a must have components to excel user experiences in the Casambi wireless environment.

Features

- Best low power load support, no bypass part or low power light adapter required
- 8 button design circuit operate and do not require system control
- Default local circuit operate and do not require system control
- 20dBm 2.4G for long range communication
- Power failure memory to return to its previous set level prior to the interruption of power
- Compatible to designer style wall plates or standard off-the-shelve wall plates
 - Fit in 1-gang U.S. wall box
 - 2 1/2" minimum depth recommended
 - Non-neutral design make installation easier (ZigBee only)
 - Available color – white
 - Face plate color (Optional)
 - A1 Dark Chocolate
 - A2 Warm Caramel
 - A3 Moon Rock
 - A4 Silver Gray
 - A5 Pebble Gray

Technical Facts

- Input : 110 ~ 277VAC/47-63Hz
- Relay switching capability : 5A/120VAC
3A/277VAC
- Operating Environment : 0 – 50 Deg.C
- Radio Properties : 2.4GHz
20dBm transfer power
- Internal Antenna : Built-in
- Controls : 2 to 8 buttons for on/off
dim
scene selection
- Dimensions : 44.40 x 33.20 x 105mm (L x W x H)

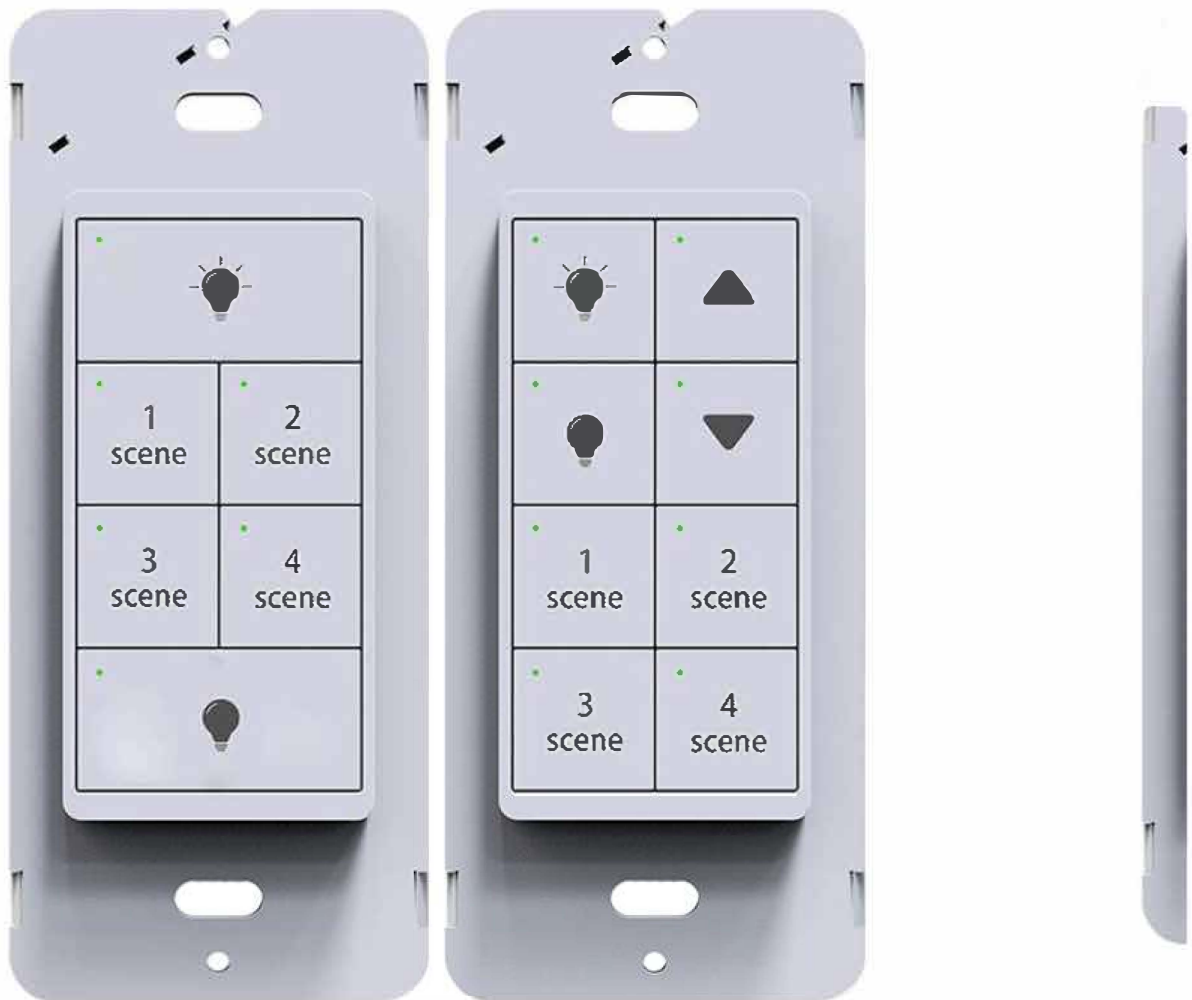

Product features

- PIR and ambient light sensor
- Supports presence, presence/absence and absence scenarios
- Ceiling surface mounting
- Battery life up to 5 years; longer runtime possible with latency optimization
- Battery operated, suitable for battery type CR123A
- Built-in magnetic trigger for hands-free pairing and OTA setup

CASAMBI 



Product specifications

168392 NASSR PDS-BAT-CAS

Input voltage	Standby current	Detection angle	RF transmit power	Casambi Fixture ID	Dimension Ø x H
2.5...3.3 Vdc	10 µA	110°	+4 dBm	40923	Ø 3.56 in x 1.05 in (Ø 90.5 mm x 26.7 mm)

Electrical specifications

Electrical parameter

Operating voltage	2.5...3.3 Vdc
Standby current	10 µA
Battery type	CR123A
RF transmit power	+4 dBm
Wireless protocol	Casambi, 2.4 GHz BLE-based proprietary mesh
Wireless range (line-of-sight, open field)	Up to 50 m

Sensor specifications

PIR axial distance (mounting height)	2.5...3.6 m
PIR axial coverage angle	110°
PIR tangential coverage angle	360°
Ambient light sensor detection range	0...3000 Lux

Control and indication

Sensitivity adjustment	4 levels, modified by buttons (see page 4 for details)
Latency adjustment	4 levels, modified by buttons (see page 5 for details)
Orange LED	Identification of devices and set mode indication
Green LED	Setting level indication

Environmental specifications

Operating temperature	0...+40 °C
Working humidity	0...+95 %

Work environment	Indoor only
------------------	-------------

Estimated battery life (reference only, no latency optimization)

Scene	Triggers per day	Estimated battery life (years)
Office corridor	100...300	5.9...10.9
Public entrance	500...2000	1.2...4.0

Dimensions

Housing dimensions

Diameter	3.56 in (90.5 mm)
Height (H)	1.05 in (26.7 mm)

For all dimensions: values in in (mm)

Packaging details

Packing units	24 pcs.
Carton size	12.32 in x 8.50 in x 7.95 in (313 mm x 216 mm x 202 mm)
Carton weight	2.07 kg
Product weight	46 g (battery not included)

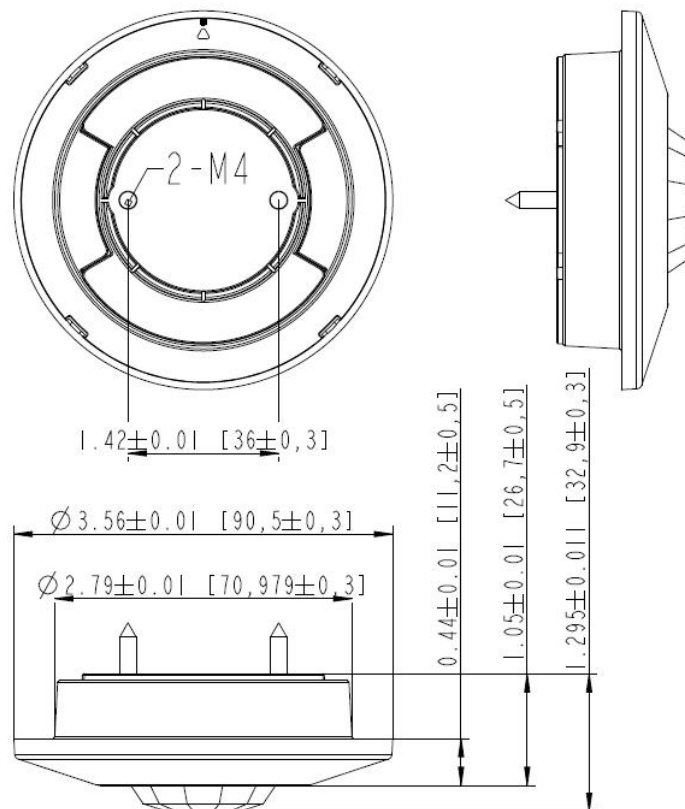

Caution

- This product is powered by CR123A battery.
- Start up time is approximately 5 s.
- No wiring required.
- Use at least 1 m away from air-conditioning vents.
- Use at least 30 cm away from luminaires.

Setting options

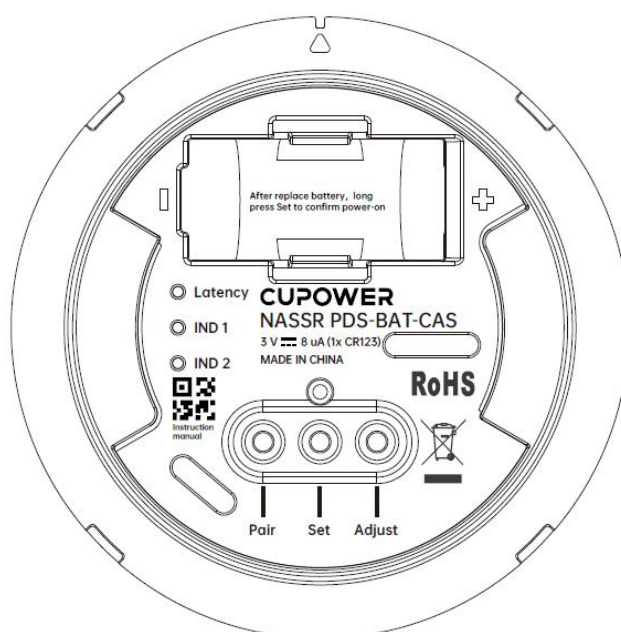

Button definition

Button	Action	Function
Pair	Enter setup mode and short press the "Pair" button (0.5 s)	Pair/Unpair
Set	Press and hold for 1 s	Enter or exit setup mode.
	Short press	Switch between sensitivity and latency settings.
Adjust	Short press	Change the level of the selected setting.

Note: See page 4 and 5 for sensitivity and latency adjustment details.

Set on sensor

1. Power on

- Insert the battery into the battery compartment. The sensor will start up. The green LED light will turn on for 3 to 5 s.
- To enter setup mode wait for start up mode to complete. Then press the "Set" button for 1 to 2 s and release it. You will see the green LED and orange LED indicators light or flash.

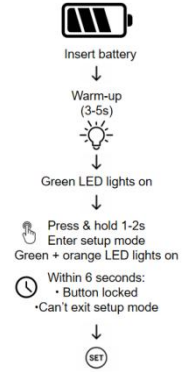

2. Sensitivity adjustment

- Short press the "Adjust" button to set the sensor sensitivity or use the default levels.

Note: Your settings will not be lost after power off.

Level	Description	Indicate	Note	Maximum ground coverage radius
1	IND2 blinking; Low sensitivity; Smaller detection range		By reducing the response sensitivity, interference in complex environments can be eliminated and false triggering can be avoided.	11.48 ft (3.5 m)
2	IND2 always on; High sensitivity; Smaller detection range		Smaller detection range, but fast response time, suitable for small space and frequent movement of people environment	13.12 ft (4 m)
3	IND2 always on; IND1 blinking; Low sensitivity; Full detection range		Large detection range but slow response time for complex office environments	13.12 ft (4 m)
4	[Factory default] IND2 always on; IND1 always on; High sensitivity; Full detection range		Large detection range and fast response time for office environments without sources of interference	16.40 ft (5 m)

3. Latency adjustment

- When the sensitivity setting is complete, short press the "Set" button to switch to the Latency setting mode and press the "Adjust" button to set the Latency.

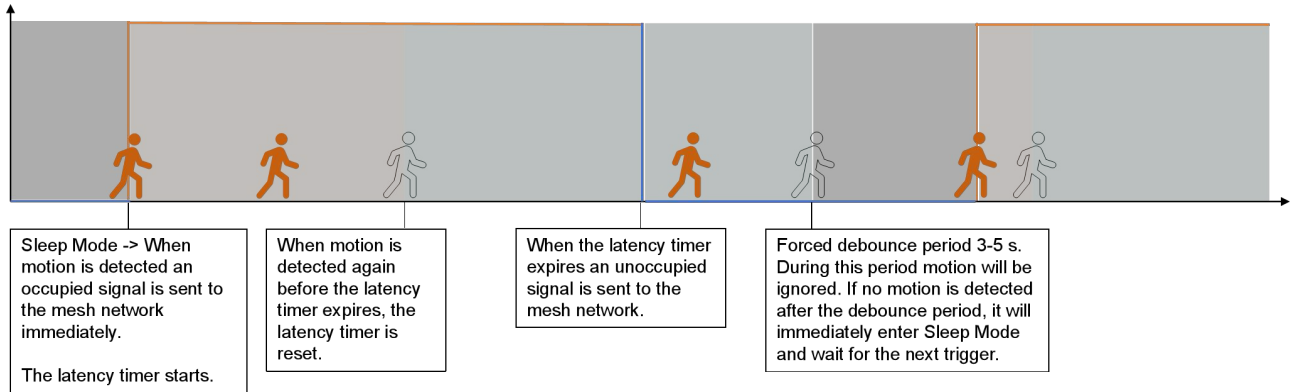

Note:

The latency setting reduces the frequency of BLE communication in unoccupied states, contributing to lower power consumption.

This parameter is independent of the **Linger time** defined in the Casambi APP:

- Latency time:** Delay before the sensor sends a "no presence" signal after motion stops
- Linger time:** Duration the light output remains ON after the "no presence" signal is sent

The effective delay after presence ends = **Latency time + Linger time**.

All configuration settings are retained after power loss.

Level	Description	Indicate	Note	Battery life
1	[Factory default] Latency always on; Indicator IND2 blinking		Latency is 0 second	More than 0.18 years
2	Latency always on; Indicator IND2 always on		Latency is 60 seconds	More than 1.8 years
3	Latency always on; IND2 always on; IND1 blinking		Latency is 5 minutes	More 6.4 years
4	Latency always on; IND2 always on; IND1 always on		Latency is 15 minutes	More 10 years

Magnetic trigger operation

Magnetic trigger area

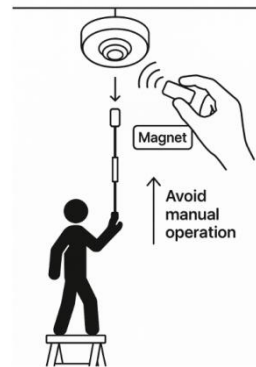
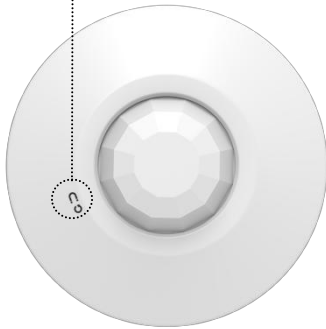

Magnetic trigger operation

The magnetic trigger provides a convenient way to re-pair or perform OTA upgrades after installation, eliminating the need to climb up and press physical buttons. Follow the steps below:

1. Attach a magnet to the end of a rod and bring it close to the magnetic trigger area on the sensor surface. Hold the magnet for 1 s, then remove it. The red LED will turn on, and the sensor will enter setup mode.
2. Within 5 s, bring the magnet close to the trigger area again. After the red LED lights up, remove the magnet. Refresh the CASAMBI app, and the option "Unpair Device" will appear.

Installation

1. Attach the base to the ceiling using matching screws.

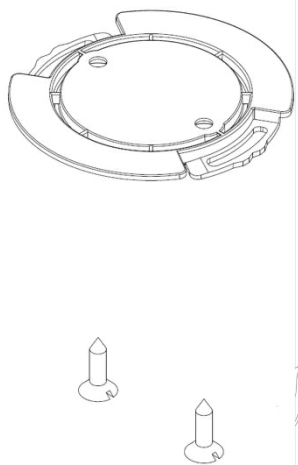

2. Install the battery, align the sensor with the base, and turn the sensor clockwise to bind to the base.

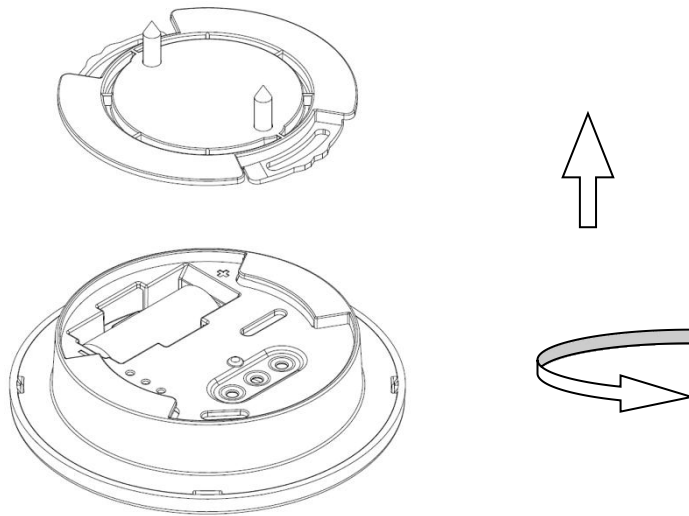

3. Installation complete, refer to setup options for sensitivity and latency adjustment.

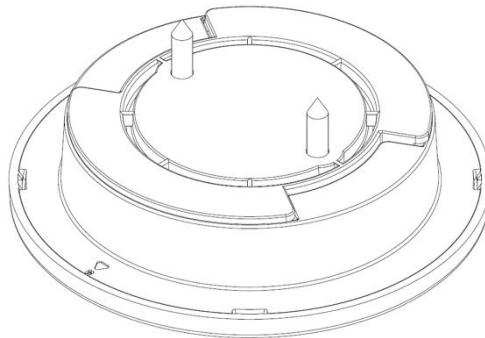

Coverage

Installation height	Coverage radius on the ground
6.56 ft (2 m)	9.84 ft (3 m)
8.20 ft (2.5 m)	12.30 ft (3.75 m)
9.84 ft (3 m)	14.76 ft (4.5 m)
11.48 ft (3.5 m)	16.40 ft (5 m)

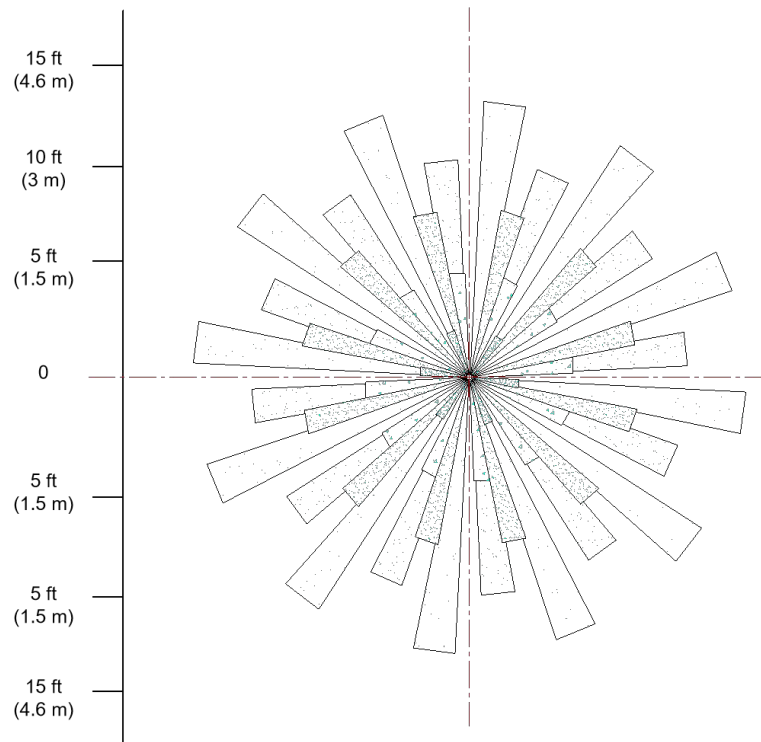

Top view

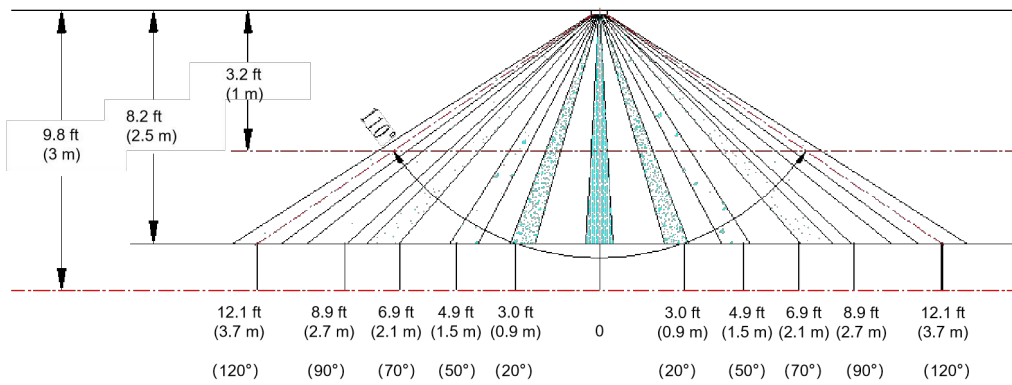

Side view



www.casambi.com



Casambi Knowledge Base



Download FREE Casambi iOS/Android App



Specification Library

Project: _____

Reference Type: _____

Item Code: _____

Date: _____

Notes: _____

Casambi Mesh Wireless Time Keeper With Battery Backup

Overview

- Master Timekeeping Node
- Surface Mounted Non-Metallic Enclosure
- Casambi Wireless Mesh
- Line Voltage Input (120-277 VAC)
- 24 Hours of Battery Backup During Power Outages
- Unit also Includes Range Extender (PSC-RET)
- ioXt Alliance Cybersecurity Certification



Suitable For Interior or Exterior Use

Applications

The PSC-TKP-200-BLE-CB provides reliable time synchronization for each node of the wireless mesh network.

PSC-TKP-200-BLE-CB features a battery backup unit to provide continuous time operation during power outages. The battery is maintained by the integrated Charge Keeper and maintains master timing for up to 24 hours.

The Time Keeper also features an integrated Range Extender to be used for maintaining mesh quality across long distances.

Wireless Control Operation

Casambi Wireless Mesh Controls: The controller connects to a Low Energy (BLE) wireless mesh network via a mobile app, available as iOS or Android, to allow initial setup and subsequent parameters adjustments.

See the mwConnect Casambi Commissioning User Manual for more information.

Summary

Product Type: Time Keeper with Battery Backup
Input Voltage: 120 to 277 VAC, 50/60Hz
Max Bluetooth Range ¹ : 900ft (274m)
Mounting: Surface Mounted Enclosure
Operating Temperature: -22°F to 158°F (-30°C to 70°C)
Storage Temperature: -40°F to 185°F (-40°C to 85°C)
Relative Humidity: 90-95% non-condensing at 30°C
Color: Gray
Warranty: 5 years

Note:
1. Bluetooth Range is highly dependent on the integration of fixtures, surrounding environment and conditions. It is recommended to conduct testing for range accuracy.



www.casambi.com



Casambi Knowledge Base



Download FREE Casambi
iOS/Android App



Specification Library

Project: _____

Reference Type: _____

Item Code: _____

Date: _____

Notes: _____

Physical Dimensions

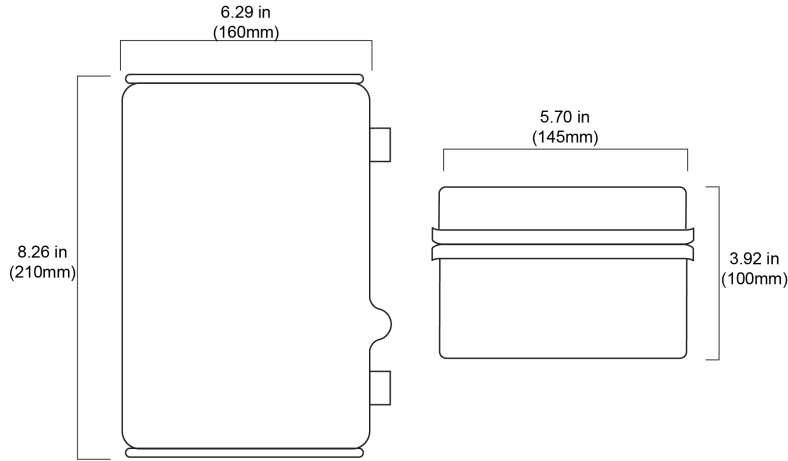

Drawings are not to scale

Internal Layout and Wiring Table

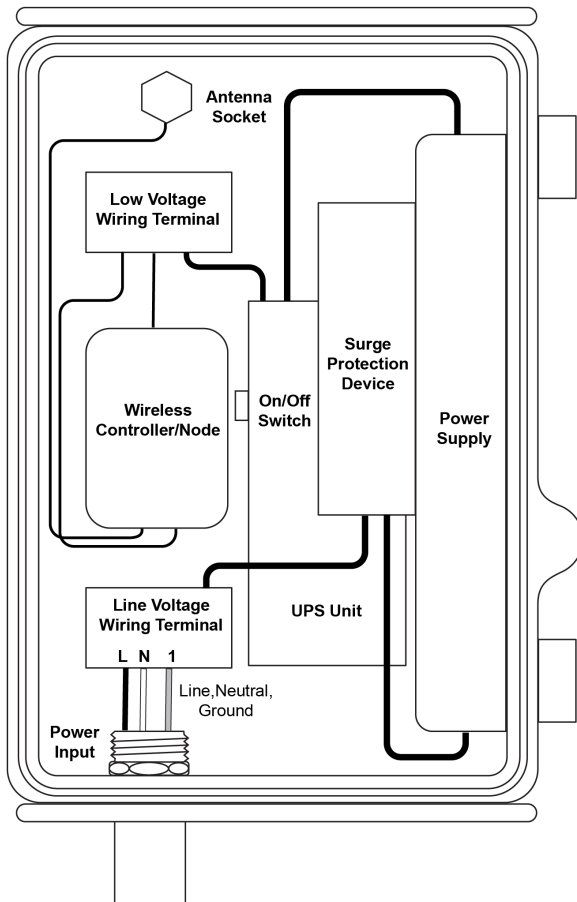

Line Terminal	Designation	Notes
Terminal L	120-277VAC Line Input	Line Input
Terminal N	120-277VAC Neutral Input	Neutral Input
Terminal 1	Ground Line Input	Ground Input

Note:
To enable battery backup, switch UPS unit to ON after installation to charge battery. Battery must charge for a minimum of 24 hours before providing backup capability.

How To Order

Model No.	Description	Input Voltage
PSC-TKP-200-BLE-CB	Casambi Mesh Wireless Line Voltage Time Keeper	120-277VAC

Design and specifications are subject to change without notice.

120-277VAC 24VDC Power Pack with Integral Relay

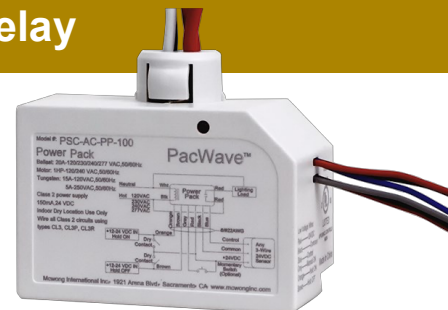

Suitable for indoor use



Overview

- Self Contained Power Pack
- Mount in Fixture or Electrical Enclosure
- 24VDC Power for Low Voltage Devices
- Rated Relay Capacity up to 20A
- Zero Cross Integral Switching Relay
- Sensor Input (Active High)
- Maintained or Momentary Inputs

Application

The PSC-AC-PP-100 Power Supply (24VDC) incorporates a line voltage transformer which can accept universal input (120-277VAC). Additional features include: Momentary Switch Input using the LVMS decora style switch, low voltage input for hold-on and hold-off. The power supply also has a 20A Zero Cross switching relay.

Typical applications include lighting controls in classrooms, lobby's, corridors, open offices, and warehouses.

Operation

The PP-100 universal voltage power pack provides 24VDC to power occupancy sensors and fixture controllers.

The PP-100 turns on and off line voltage in response to occupancy sensors and switch inputs.

The power supply can be mounted on a JBOX or light fixture.

Summary

Product Type:
Power Pack

Input Voltage | Current Consumption:
120V or 277V, 50/60Hz | 5.5W

Load:
20A@ 120/277 VAC (ballast)
20A@ 120VAC (incandescent)
Motor 1 HP @120/240

Output: 24VDC, 150 mA

Switch Input: Momentary Input

Switch Input: 12-24VDC Input for Hold On

Senor Input: Active High Input

Mounting
Fixture or JBOX Mount

Max Case Temperature:
90°C

Operating Temperature:
-30° C to 70° C

Storage Temperature:
-40° C to 80° C

Relative Humidity:
90-95% non-condensing

Color: White

Warranty: 5 years

Wiring Example Application: Controller Installed In Electrical Enclosure, Low Voltage Wired Sensor And Switch

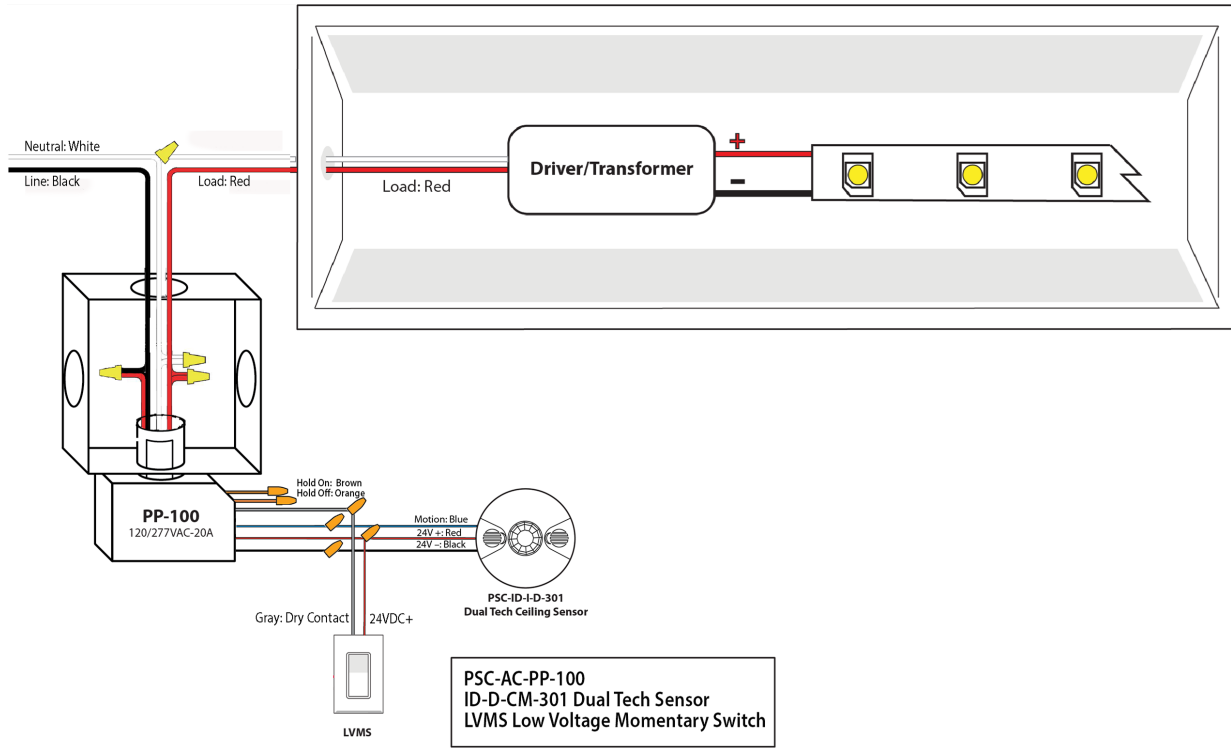

Wiring Example Application: Controller Installed In Electrical Enclosure, Network Application

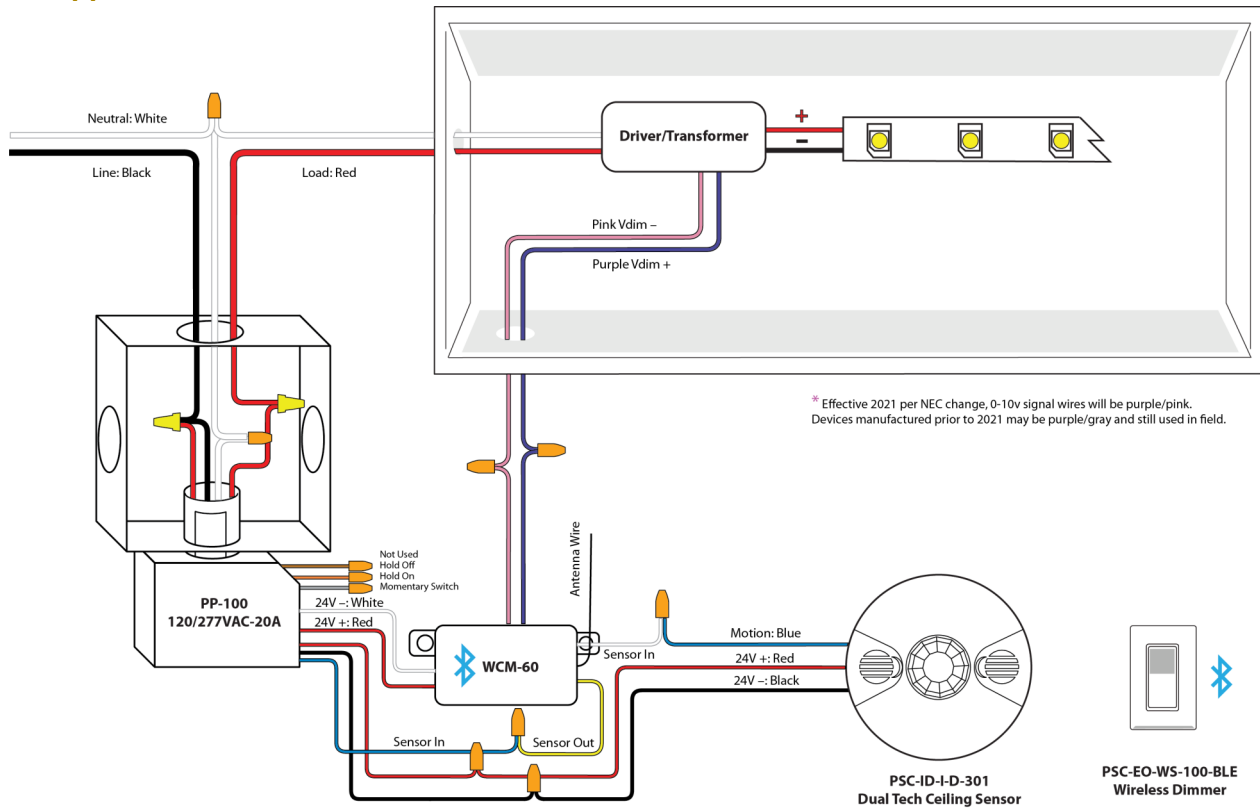

Dimensions

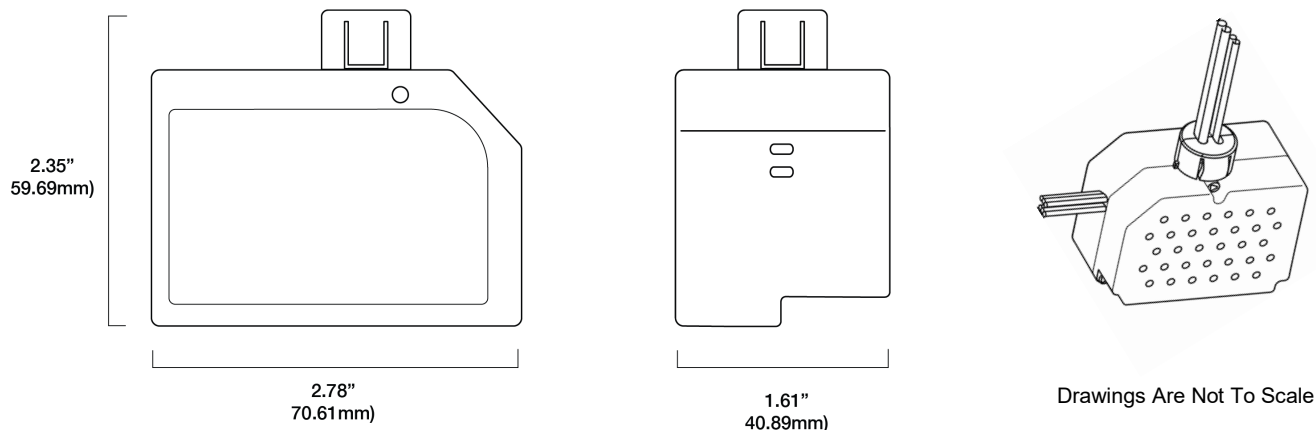

Drawings Are Not To Scale

Wiring Table

Wire	Designation	Notes	Size
Black	Line Input	Connect to Line Power	#12 AWG, 300V 105+/- 20mm, Strip 10mm, Tin Plated
White	Neutral Input	Connect to Neutral Power	
Red	Load Output	Connect to Luminaire Power Input	
Red	12VDC+ Power Output	Connect to Sensor Power Input (12V+)	#22 AWG, 300V 110+/- 10mm, Strip 10mm Tin Plated
Black	12VDC- Power Output	Connect to Sensor Power Input (12V-)	
Blue	Control Input	Connect to Sensor Output or Similar Device	
Orange	12-24VDC In	Connect to Dry Contact for Hold On	
Brown	12-24VDC In	Connect to Dry Contact for Hold Off	
Gray	Momentary Switch Input	Connect to Momentary Switch for On/Off	

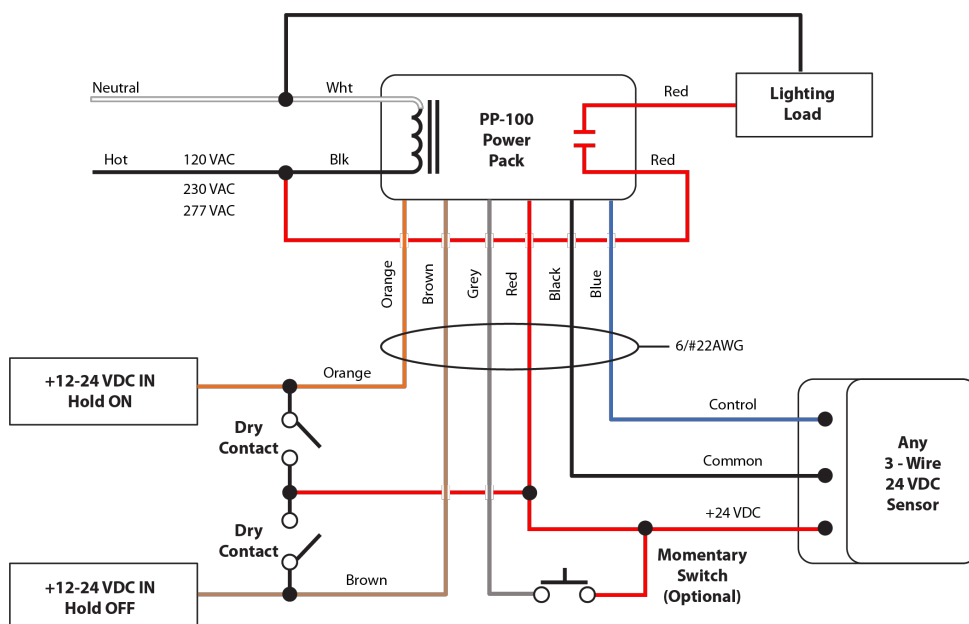

How to Order

Model No.	Description	Input Voltage	Output
PSC-AC-PP-100	Line Voltage Power Supply with 120-277 VAC 20A Relay, Fixture or Electrical Enclosure Mounting	120-277VAC	24VDC

Design and specifications are subject to change without notice.